

Digilab 2

FPGA Development Board

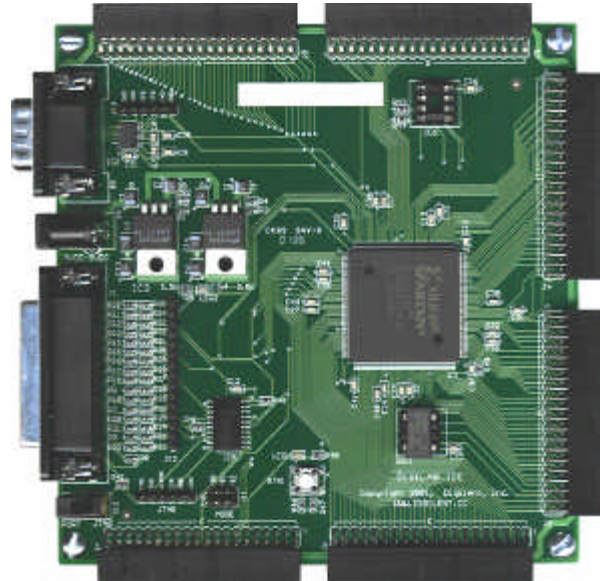

The Digilab 2 (D2) FPGA-based development board makes an excellent prototyping platform for moderate to complex digital circuits and systems. The D2 board features a 200K-gate Xilinx Spartan 2 XC2S200 FPGA in a PQ208 package that provides 143 user I/Os. All available I/O signals are routed either to the expansion connectors, or to the ports and other on-board devices. A single on-board pushbutton and LED allow for quick circuit and device programming checks, as well as basic I/O (e.g., for reset and status). The D2 board mates with several existing peripheral boards so that entire digital systems can be quickly and easily constructed. The D2 board works seamlessly with the free WebPack CAD tools, and it ships with a programming cable and power supply, so projects can be implemented immediately, without the need for any other components or expenses.



Digilab 2 (D2) Development Board

D2 board features include:

- A Xilinx XC2S200 FPGA in a PQ208 package offering 143 user I/O signals;
- Dual on-board 1.5A power regulators (2.5V and 3.3V);
- A socketed 50MHz oscillator;
- A socket for a Xilinx SPROM;
- EPP-capable parallel port for JTAG-based FPGA programming and user data transfers;
- A separate JTAG header for use with Xilinx parallel 3 or parallel 4 programming cables;
- 5-wire RS-232 serial port;
- Status LED and pushbutton for basic I/O;
- 6 100-mil spaced, right angle DIP socket 40-pin expansion connectors.

For more information, please see the Digilab 2 reference documents available at our website.

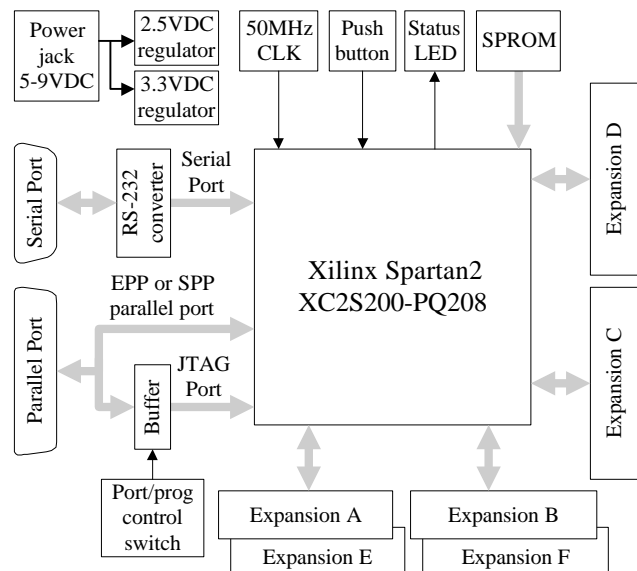

D2 Block Diagram