

# GR series

- Stand product, for general purposes.
- 標準品、普通用途。

## SPECIFICATION

Item 項目	Character 特性											
Capacitance Tolerance 靜電容量容許差	±20% (120Hz, 20°C)											
Operating Temperature Range 適用溫度範圍	-40 ~ +105°C						-25 ~ +105°C					
Voltage Range 工作電壓範圍	6.3 ~ 100V						160 ~ 450V					
Leakage Current 洩漏電流	I ≤ 0.02 CV or 3 ( uA), which is greater. (After 3 minutes application of working voltage)						I ≤ 0.03 CV + 40uA , (After 3 minutes application of working voltage)					
Dissipation Factor 散逸因素( 損失角正切) ( tan )	Measurement Frequency: 120 Hz. Temperature: 20°C											
	Rated Voltage (V)	6.3	10	16	25	35	50	63	100	160~ 250	350~450	
	tan (MAX)	0.24	0.20	0.16	0.15	0.12	0.10	0.09	0.08	0.20	0.25	
Low Temperature Stability 低溫特性 Impedance Ratio (MAX) 阻抗比率	Measurement Frequency: 120Hz.											
	Rated Voltage (V)	6.3	10	16	25	35	50	63	100	160~ 250	350~ 400	450
	Z (-25°C) / Z (20°C)	5	4	3	2	2	2	2	2	3	6	15
	Z (-40°C) / Z (20°C)	12	10	8	6	4	3	3	3	4	-	-
Load Life 高溫負荷壽命	1000 hours, with application of working voltage at 105°C											
	Capacitance Change	Within ±20% of Initial Value										
	tan	200% or less of Initial Specified Value										
	Leakage Current	Initial Specified Value or less										
Shelf Life 高溫放置壽命	1000 hours, no voltage applied, at 105°C											
	Capacitance Change	Within ±20% of Initial Value										
	tan	200% or less of Initial Specified Value										
	Leakage Current	Initial Specified Value or less										
Standards 標準參照	JIS C 5141 and JIS C 5102											

## RIPPLE CURRENT COEFFICIENTS

### Temperature Multiplies

TEMP (°C)	40	60	105
Coefficient	1.30	1.25	1.00

### Frequency Coefficient of Allowable Ripple Current

WV (V)	Capacitance (uF)	Frequency (Hz)			
		50	120	1K	≥ 10K
≤ 100	< 100	0.75	1.00	1.57	2.00
	100~470	0.80	1.00	1.34	1.50
	> 470	0.85	1.00	1.10	1.15
≥ 160	< 330	0.80	1.00	1.40	1.60
	≥ 330	0.90	1.00	1.13	1.15





# Taping Specifications

## Taping:

Fig.1 : Formed

TA · TR

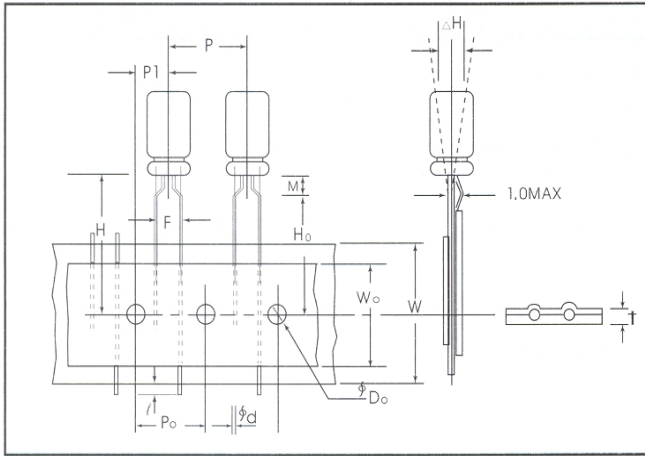
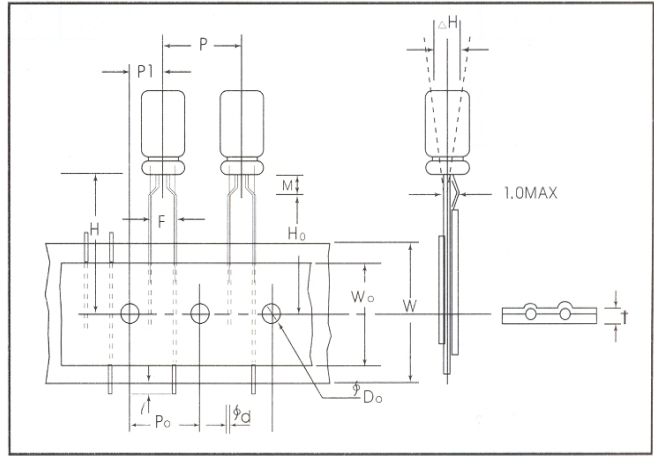

Fig.2 : Straight ( 10 — 13 φ )

HA · HR



## DIMENSIONS:(mm)

Item	Symbol	TA · TR		HA · HR	
		Nominal Value	Tolerance	Nominal Value	Tolerance
Lead-wire diameter	$\phi d$	0.5	$\pm 0.05$	0.5	$\pm 0.05$
Pitch of component	P	12.7	$\pm 1.0$	12.7	$\pm 1.0$
Feed hole pitch	P <sub>0</sub>	12.7	$\pm 0.3$	12.7	$\pm 0.3$
Feed hole center to component center	P <sub>1</sub>	6.35	$\pm 1.3$	6.35	$\pm 1.3$
Lead to lead distance	F	5.0	-0.2 + 0.8	4 φ , 5 φ , 6.3 φ 2.5	8 φ 3.5 -0.2/ + 0.8
Lead to lead distance	F <sub>1</sub>	—	—	5.0	+0.5/ -1.0
Clinch dimension	K	L ≤ 9 1.5 L > 10 2.5	MAX	—	—
Height of component from tape center	H	L ≤ 9 17.5 L > 10 18.5	0.75	18.5	0.75
Lead-wire clinch height	H <sub>0</sub>	16.0	$\pm 0.5$	16.0	$\pm 0.5$
Tape width	W	18.0	-0.5 / +1.0	18.0	-0.5 / +1.0
Hole-down tape width	W <sub>0</sub>	12.5	MIN	12.5	MIN
Feed hole diameter	$\phi D_0$	4.0	$\pm 0.2$	4.0	$\pm 0.2$
Total tape thickness	t	0.7	$\pm 0.2$	0.7	$\pm 0.2$
Component alignment, F - R	$\Delta H$	0	$\pm 2.0$	0	$\pm 2.0$
Lead-wire protrusion	l	2.0	MAX	2.0	MAX

\*For D=0, H=20.0 ± 0.75 is available, in this case, the dimension of H is not specified

## Figure 2 : PACKAGING

2-1, Ammo pack box

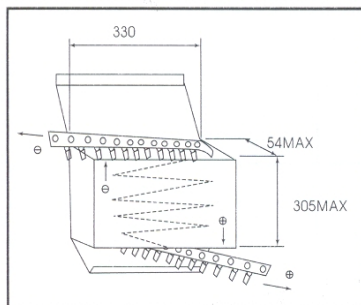

2-2, Reel pack box

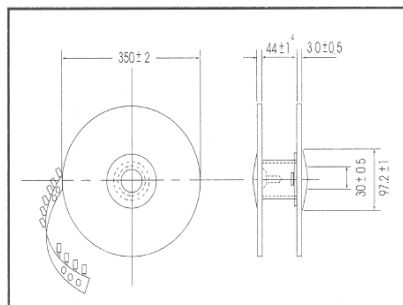

## Packaging Quantity

$\phi D$	4	5	6.3	8
Case Height	5.7	5.7,11	5.7,11	9.12
TA · HA	2500	2000	1600	1000
TR · HR	1500	1250	1000	800

Note ) Above quantities are principle.

Some difference may be provided.

Note ) The component shall be oriented on the tape as such that the load is leading or the negative load is loading with customer's request.

# Lead Forming & Life Chart

## Lead Cutting, Forming, Bending and Crimping

(1) General

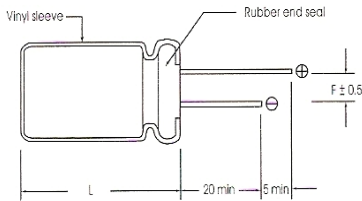

Dφ	4	5	6	8	10	13	16	18
F	1.5	2.0	2.5	3.5	5.0		7.5	
dφ	0.45	0.5		0.6			0.8	

(2) Shape A

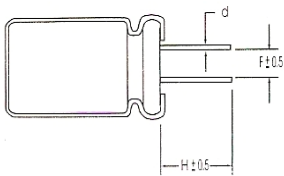

(3) Shape B

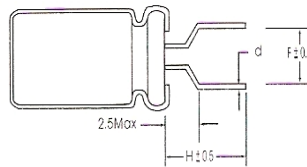

(4) Shape C

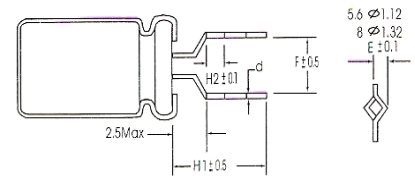

(5) Shape D

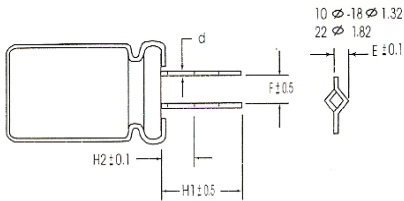

(6) Shape E

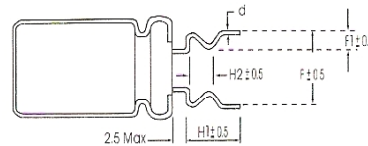

(7) Shape F

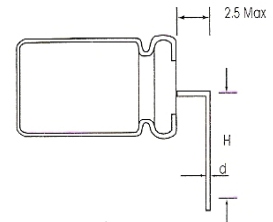

## Specification Information:

Shape No.	Cutting & Forming Methods	Dφ	4φ	5φ	6φ	8φ	10φ	13φ	16φ	18φ
A	Lead Cutting Only	F	1.5	2.0	2.5	3.5	5.0	5.0	7.5	7.5
		H	4.0	4.0	4.0	4.0	5.0	5.0	5.0	5.0
		d	0.45	0.5	0.5	0.6	0.6	0.6	0.8	0.8
B	Lead Cutting and Forming	F	5.0	5.0	5.0	5.0	—	—	—	—
		H	4.0	4.0	4.0	4.0	—	—	—	—
		d	0.45	0.5	0.5	0.6	—	—	—	—
C	Lead Cutting, Crimping and Forming	F	5.0	5.0	5.0	5.0	—	—	—	—
		H1	4.0	4.0	4.0	4.0	—	—	—	—
		H2	1.8	1.8	1.8	1.8	—	—	—	—
D	Lead Cutting and Crimping	F	—	—	—	—	5.0	5.0	7.5	7.5
		H1	—	—	—	—	4.5	4.5	4.5	4.5
		H2	—	—	—	—	1.8	1.8	1.8	1.8
E	Lead Cutting and Forming	F1	5.0	5.0	5.0	5.0	—	—	—	—
		F2	1.2	1.2	1.2	1.2	—	—	—	—
		H1	4.0	4.0	4.0	4.0	—	—	—	—
F	Lead Cutting and Bending	F	1.5	2.0	2.5	3.5	—	—	—	—
		H	6.0	7.0	8.0	9.0	—	—	—	—
		d	0.45	0.5	0.5	0.6	—	—	—	—

## 鋁質電解電容器使用需知

1. 在電氣回路如不清楚或不明確線路之極性時，則建議使用無極性電解電容器。
2. 無極性 (或二極性) 電解電容器，可使用在極性轉換的回路或直流回路上。
3. 單極性電解電容器只能使用在直流電路上，其極性必需標明在適當之位置或在導針/端子之旁邊。
4. 電解電容器應儲存於低溫及乾燥之處所。
5. 電解電容器不可使用在周圍溫度超過所標示之使用溫度範圍。
6. 電解電容器不適用於超過可容許紋波電流範圍之回路之上，假如有需要耐高紋波電流之電解電容器，請與我們洽商詳情。
7. 電解電容器如經長久儲存，如果漏電電流超出規格值，使用前應以額定電壓重新再充電 30~60 分鐘。
8. 電解電容器一般品不適用於瞬間之充放電，如需要使用在快速充放電的場合，請與我們洽商。
9. 使用於電解電容器之工作電壓，不得超過其額定電壓。
10. 爲了保護電解電容器之內部結構，其導針或端子不容許過份之拉力或承受的拉力。
11. 電烙鐵應與電容器塑膠管保持適當距離，以防止過熱造成塑膠套管破裂。
12. 電解電容器經波峰之程序，其焊錫槽之溫度絕對不容許超過 240°C，時間 5 秒鐘。
13. 爲了保護塑膠套管、印刷標示以及封口材料不被破壞，電解電容器不得以鹵化化學藥品或類似溶劑，作爲電解電容器洗滌之用，如三氯乙烯、二甲苯類或銅類等。
14. 本公司尺寸僅供設計線路參考，本公司得視現有材料做規格設計變更尺寸，訂購前可再與本公司確認。

## 環保對策

- 一 本公司積極推動地球環保政策；
- 一 生產過程不使用破壞臭氧層的化學物質；
- 一 產品不使用含鉛、鎘等對人體有害物質的材料。

## PRECAUTIONS IN USING ALUMINUM ELECTROLYTIC CAPACITORS

1. If circuit polarities are unclear or uncertain, Non-polar capacitors are recommended.
2. Non-polar (or Bi-polar) capacitors can be used in polarities changing circuits or DC circuits.
3. Polarized capacitors can be used in DC circuits only. Its polarity must be marked on the proper side of lead wire/terminal.
4. Capacitors should be stored at a place of cool and dry.
5. Capacitors can not be used in a place of ambient temperature exceeding its marked temperature.
6. Capacitors can not be used in a circuit whose ripple current exceeding permissible ripple current.  
If high ripple current resistant capacitors are required, please contact us.
7. If capacitors have been stored for a long time and its leakage current exceed the specified value,  
Please recharge for 30 to 60 seconds with rated voltage before using.
8. Capacitors can not be used in a circuit of sudden charge or discharge, if used in a circuit of sudden charge or discharge is required, please contact us.
9. Application of working voltage to capacitors should not exceed its rated voltage.
10. In order to protect inside structure, capacitors can not be applied with over pull-force.
11. Soldering irons should be kept away from vinyl sleeve of capacitor in order to avoid cracking of sleeve.
12. For peak soldering, the solder temperature should not be over 240°C for 5 seconds to capacitors.
13. In order to protect sleeve, printed marks and sealing material, capacitors can not be cleaned with halogenated chemicals or similar solvent such as Trichloroethylene, Xylene or Acetone, etc.
14. All or size and dimensions are offering for reference on design, please confirm the exact dimension before your purchase.

## MEASURES TAKEN FOR ENVIRONMENT PROTECTION

- Actively promoting Environment Protection Policies
- No ozone unfriendly chemicals is used in our production processes
- No lead and cadmium of hazardous elements is used in our products

# Automatic Production Flow Chart

